

# THE ATMOSPHERIC HEAT PUMP

By: Rudolph N.J. Draaisma  
email: [engineering@draaisma.net](mailto:engineering@draaisma.net) website: <http://draaisma.net>

Phnom Penh, Tuesday, May 03, 2011

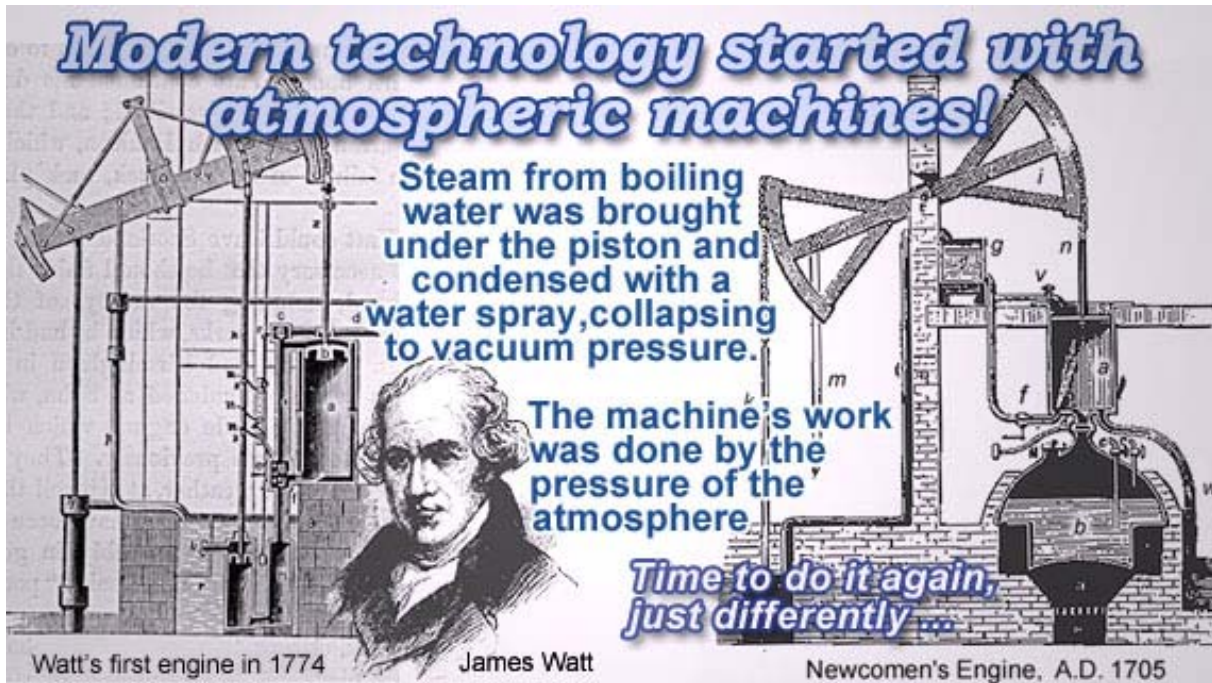

## INTRODUCTION

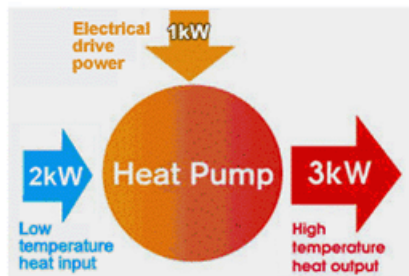

In a regular heat pump, as shown here, electrical power is used to bring an internal fluid (refrigerant) on a low temperature on its cold side and on a high temperature at its hot side.

The cold side absorbs heat from the outside air (solar energy!) and

The hot side gives off that heat, PLUS the drive power to your home. The Coefficient OF Performance (COP) is then the output power, divided by the drive power. The COP = 3 in the image example.

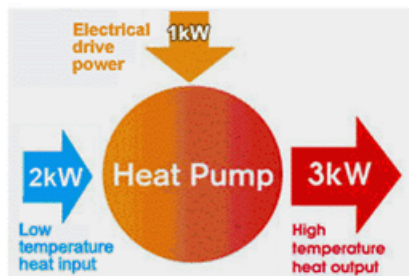

HOWEVER, the larger the temperature difference between the hot and the cold set gets, the lower the COP becomes.

At very cold weather, like  $-10^{\circ}\text{C}$  ( $14^{\circ}\text{F}$ ), and lower, the COP gets close to 1, or even less. You then could cheaper use an electrical heater instead.

An air-to-air heat pump is very expensive and a ground based one, needed in very cold climate zones, is far more expensive as to its installation costs. **The atmospheric heat pump is a cheap design and its COP is INDEPENDENT from temperature differences!**

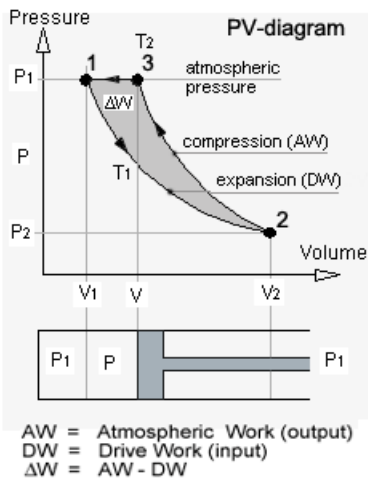

## THE ATMOSPHERIC HEAT PUMP

A volume ( $V_1$  at point 1) of ambient air is expanded to a larger volume ( $V_2$  in point 2), by pulling out a piston in a cylinder, by which the pressure decreases to  $P_2$ .

This is so called free expansion, by which the temperature ( $T_1$ ) doesn't change. The drive work (DW) for this is done on the atmosphere.

In the following, the air flow is 1 kg/s,  
 $P_1 = 1 \text{ bar}$ ,  $P_2 = 0.2 \text{ bar}$ ,  
 $T_1 = 0^\circ\text{C}$  ( $32^\circ\text{F}$ ) and **DW = 180 kW**

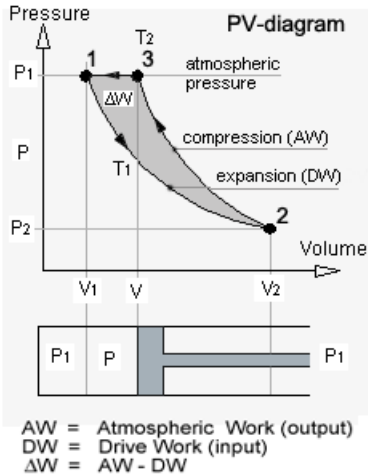

Next, we let the atmosphere compress the air back to atmospheric pressure, from point 2 to 3. This is so called adiabatic compression, by which the air gets hot at  $T_2 = 254^\circ\text{C}$  ( $490^\circ\text{F}$ ).  
 (no regular heat pump could do this!)

Thereafter the air is further pushed out into the home's heating system, where it cools down, finally becoming ambient air at  $P_1$ ,  $T_1$  again (cycle closed).

The atmosphere does all the work for this and **AW = 255 kW**, which is  $\Delta W$  (75 kW) more than we put in and the  
**COP = 255/180 = 1.42**

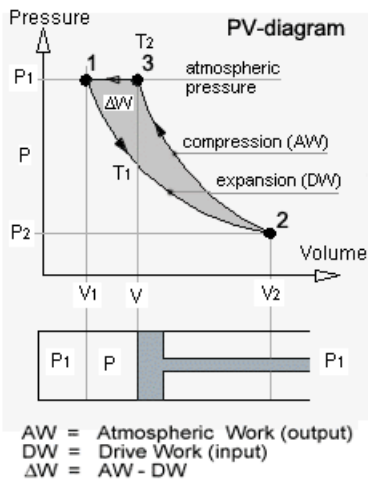

The COP calculates as:

$$\text{COP} = \frac{C_p \left[ \left( \frac{P_1}{P_2} \right)^n - 1 \right]}{R \cdot \ln \left( \frac{P_1}{P_2} \right)}$$

where  $C_p$ ,  $R$  and  $n$  are gas constants.  
 We see thus that temperatures have no influence on the COP

While a regular heat pump could not, an atmospheric heat pump could still make you a cheap, hot cup of coffee on the North Pole!

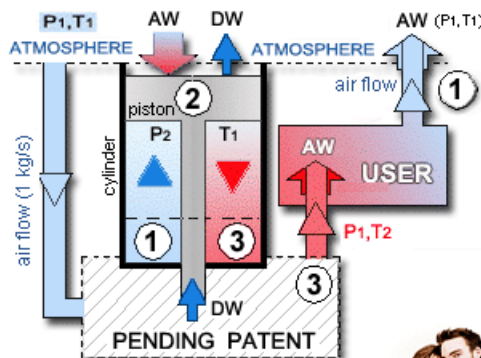

## SUMMARY

The atmosphere thus gave 75 kW free power (which actually is solar energy!) at a COP of 1.42

This saves you ~25% on your electricity bill, with a cheap machine, that doesn't use harmful refrigerants! Can it be more environmental friendly?

- ② State-points in the PV-diagram  
 DW = Drive power: 180 kW  
 AW = Atmospheric power: 255 kW  
 COP = Coefficient Of Performance



**Your investment would be earned back in years, instead of decades with a regular heat pump!**

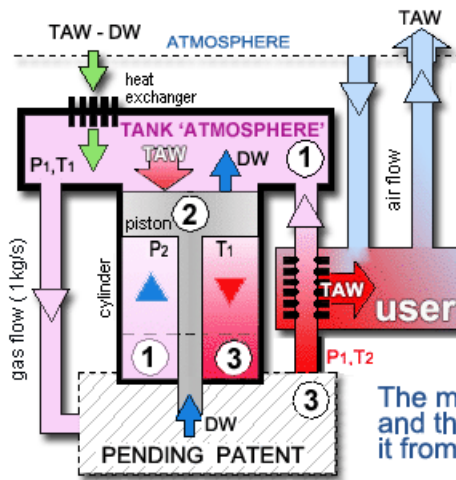

It gets even better with the: **SEMI-ATMOSPHERIC HEAT PUMP**

Do you think a heat pump without a cold side violates the Second Law of Thermodynamics?

OK, then we create a cold side, simply by placing the machine in a gas filled tank, thus giving it an 'atmosphere' of its own, that we can pressurize as well, so as to decrease the machine size.

**GRREAT!**

The machine still needs its extra 75 kW, and thus the tank gets cold, to absorb it from the surrounding air.

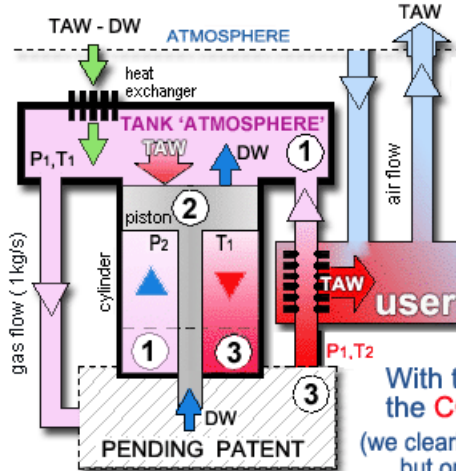

We thus have created a cooling effect and if we make use of it, the **COP = (255+75)/180 = 1.83** a saving of ~45% on a home's electricity bill (see next page).

If we instead of air use a nobel gas, like Argon, in the tank, the **AW = 215 kW, DW = 130 kW, T<sub>2</sub> = 415 °C (780 °F - enough to drive a steam turbine with!) and a COP of 1.64**

With the cooling effect of 85 kW added, the **COP = 2.31**

(we clearly see that energy cannot be 'consumed', but only spread out to a lower temperature)

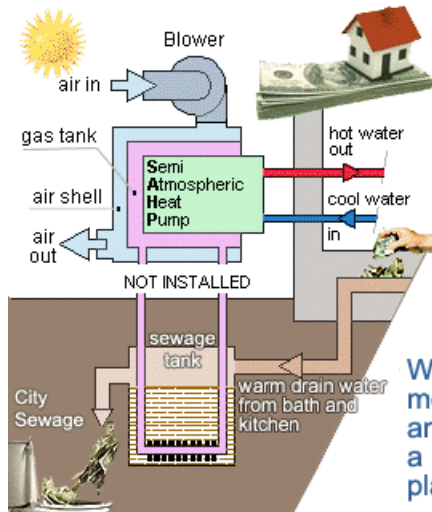

**HOME ENERGY ECONOMY**

Do you have any idea how much money you're flushing away every day with warm waste water from bath and kitchen?

For example: 100 liter/day, heated up with 40 °C (105 °F), it amounts to a whole 140 kWh per month and you wasted it almost as warm as you used it!

With the SAHP you can recover most of it. Homes usually have an own sewage tank, in which a heat exchanger tank could be placed, as shown here.

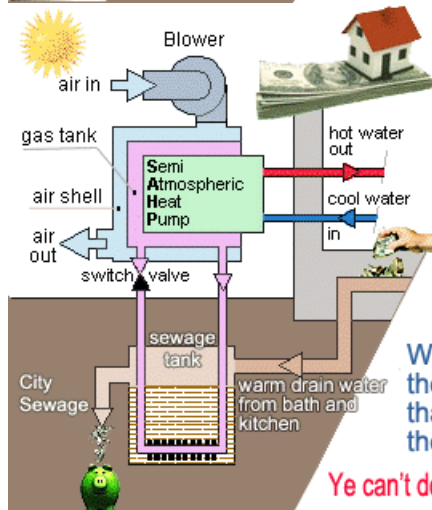

The temperature of the gas tank always clamps to that of its surroundings; it has no "own" temperature, like the evaporator of a regular heat pump has.

If clamped on the sewage tank, the gas tank temperature will be below that of the sewage tank and cool it down to any lower temperature.

When the sewage tank is almost frozen, the circuit switches to that of the blower, that starts running to extract energy from the outside air, at any other temperature.

**Ye can't do this double function with a regular heat pump!**

## THE PRACTICAL CASE

Usually a practical machine performs worse than in the theoretical ideal case. System analysis shows however, that heat leakage from the warm cylinder wall and piston into the expanding gas, actually increases the COP!

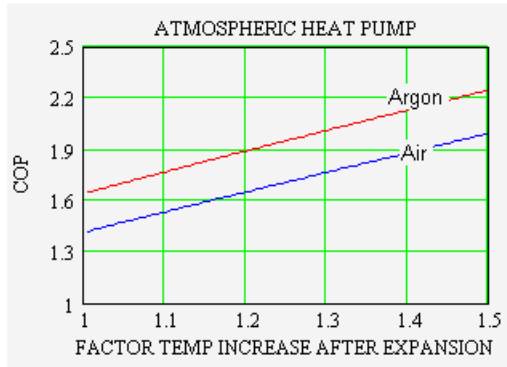

There are of course other factors, such as friction, that decrease the overall performance, but there clearly is good reason to hope for at least the same overall performance as in the ideal case.

There are margins!

## Would you like to install an Atmospheric Heat Pump in your home?

Then you better spread the word about it, cause at present it exists only in this video and in my head.

Perhaps some day, some developer might want to bring it on the the market?

The Business will be fully his; the NAME will be fully mine!

Meanwhile I would like to assist in the development as a paid consultant.

Not asked too much, is it?



*The inventor*



What I mean to say is that I have no claims on intellectual property, just that any patents have my name as that of the sole inventor. The developer can be the applicant and owner of the granted patent(s).

As a paid consultant I will compose the patent description(s), ready for submission by others.

I will also be the contact person for the Examiner – no patent attorneys 'messing' things up.

(I had 'horrible' experiences with that)